

ELECTRIC CHARACTERISTICS

Nominal Voltage	0/600 V _{ac} - 50/60 Hz
Phase to phase test voltage	2700 V _{dc} (2 s)
Phase to ground test voltage	3200 V _{dc} (2 s)
Climatic class	-25 / +85 °C



FIN1700IT	Nominal current (A)		Cy1 (nF) ± 5%	L1 (mH) ± 10%	L2 (mH) ± 10%	Pow loss (W)
	TA=40°C	TA=55°C				
.006.M	3X8	3X6	100	1,5	1,5	8
.012.M	3X14	3X12	100	1,5	1,5	10
.016.M	3X18	3X16	100	1,4	1,4	12
.025.M	3X28	3X25	100	1,3	1,3	15
.032.M	3X35	3X32	100	1,2	1,2	23
.042.M	3X50	3X42	100	1,1	1,1	32
.055.M	3X63	3X55	100	1,1	1,1	37
.070.M	3X80	3X70	100	1	1	52
.080.M	3X90	3X80	100	1	1	60
.100.M	3X110	3X100	100	0,9	0,9	92
.115.M	3X130	3X115	100	0,8	0,8	101
.150.M	3X175	3X150	100	0,7	0,7	115
.200.M	3X230	3X200	100	0,6	0,6	120

Total leakage current at 230 V phase to ground 50 Hz / 40°C < 3mA

FIN1700IT ELECTRIC DIAGRAM

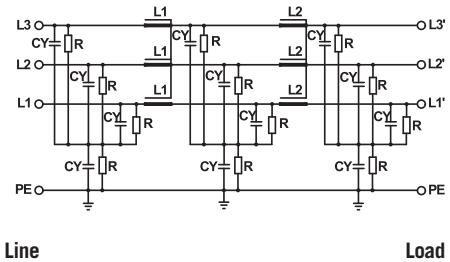

Models available with current rating up to 1500A

MECHANICAL DIMENSIONS (mm)

FIN1700IT	A	B	V	V1	F	H	I	L	N	d	Weight Kg
.006.M/.012.M	140	50	19	15	6	226	200	7	28	M6	1,7
.016.M	177	60	19	15	6	267	237	8	34	M6	1,7
.025.M/.032.M	177	60	19	15	6	267	237	8	34	M6	2,3
.042.M	177	70	19	35	6	295	265	8	44	M6	3,4
.055.M	177	70	19	33	6	295	265	8	44	M6	3,5
.070.M/.080.M	205	80	28	38	8	390	340	12	53	M10	6
.100.M/.115.M	205	80	28	43	8	390	340	12	53	M10	7,1
.150.M/.200.M	220	105	28	50	8	420	370	12	78	M10	8

TERMINAL BLOCK (mm²)

Terminals	Rigid Cable	Flexible Cable
K6	0.2 - 10	0.2 - 6
K6	0.2 - 10	0.2 - 6
K6	0.2 - 10	0.2 - 6
K10	0.5 - 16	0.5 - 10
K16	0.5 - 25	0.5 - 16
K25	6 - 35	10 - 25
K50	16 - 50	16 - 50
K95	25 - 95	35 - 95

INSERTION LOSS

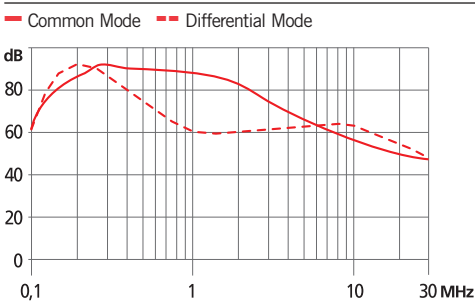

CASE

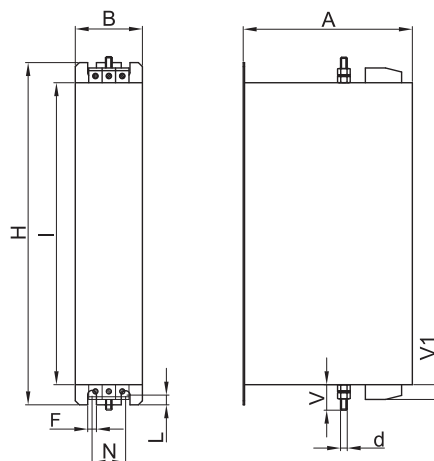

ASSEMBLING

