

Enerdoor motor protection reduces harmful  $dV/dt$  generated by variable frequency drives imposed onto the motor. Motor protection devices are designed to work in various applications of switching frequencies and frequency outputs.

This series carries CE and UL approvals and offers a current range from 3 to 1000A. Enerdoor motor protection includes common mode and differential mode inductance, sine wave filters and snubbers.

Unique features include: high linearity vs frequency and current, very low operating temperatures, and compact dimensions.

The FIN960F high frequency inductance is a unique solution used for synchronous spindle motor applications. This line works with very low temperatures and frequency output up to 2 kHz while allowing the motor to operate at a low temperature.

The FIN905SF and FIN915SFH sine wave filters reduce the PWM effect, convert the PWM to a sine wave and eliminate  $dV/dt$ . These lines work with applications in open or closed loop feedback.

The FIN905SF works with frequency output up to 70 Hz. The FIN915SFH line is used with fundamental frequencies up to 2 kHz while maintaining a very low application temperature.

### Motor protection applications include:

- Motors controlled by drives
- Pumps and conveyors
- Automated machinery
- Spindle motors closed loop
- High speed motors/ pumps
- CNC Machines
- Long cable applications  
2,500m (8,200 ft)
- Process plants
- Water treatment plants
- Packaging equipment

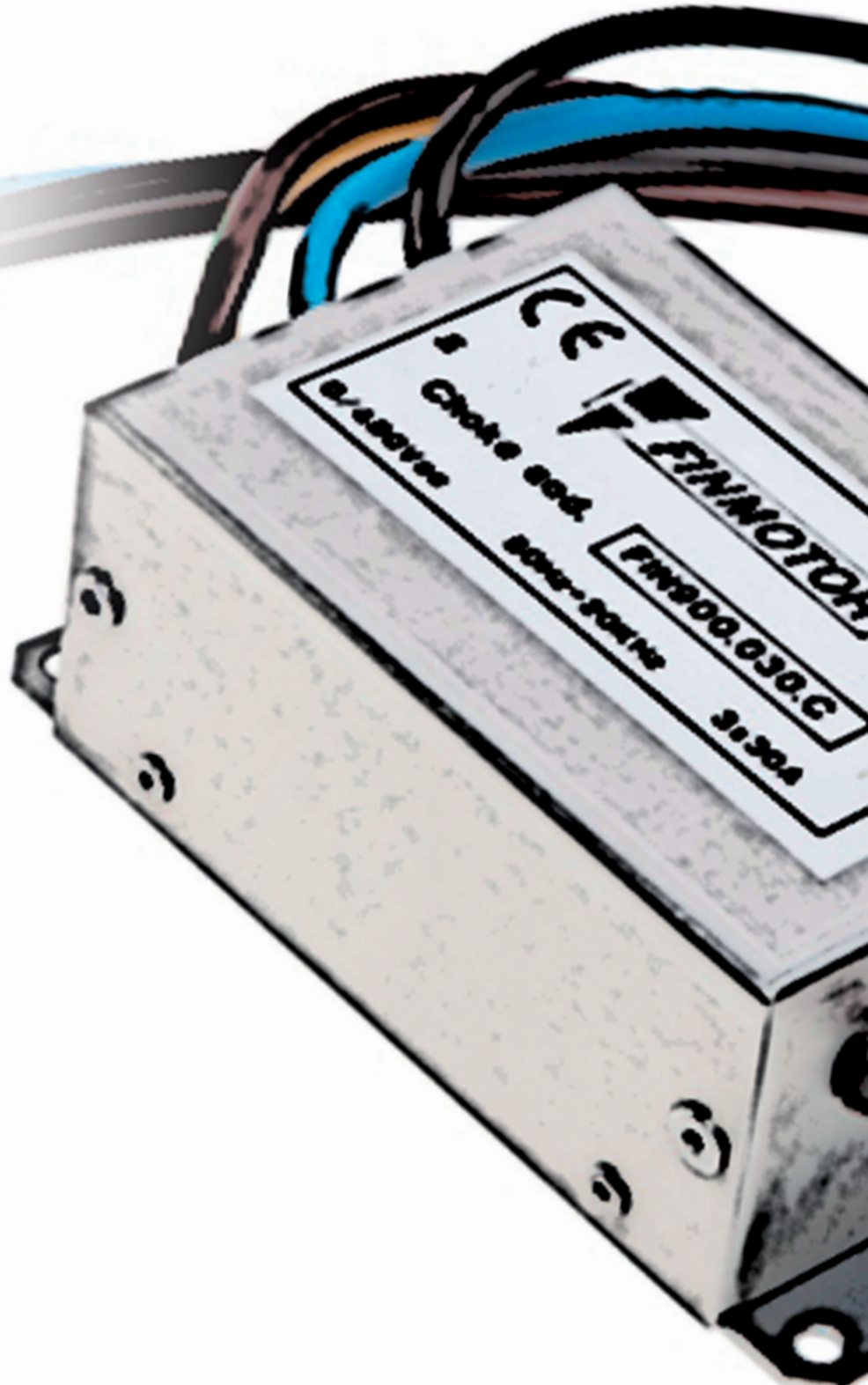



## Common mode choke with high attenuation for reducing dV/dt and high frequency

Datasheet 3/2017

**APPROVALS:**

**FIN900.(010 - 030).1C**
**FEATURES**

- 5 Year warranty
- Protects against voltage spikes on the motor
- Compact design

**BENEFITS**

- Rated current from 10 to 280A
- Reduces voltage rise and high frequency
- Helps pass European emission Standards

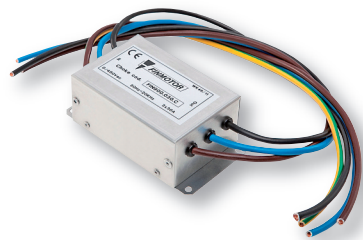

**FIN900.(010 - 030).C**
**MARKETS**

- Motors controlled by drives
- Pumps
- Conveyers
- Automated equipment

**ORDERING CODE**

FIN900	.016	.1C
Model	Current (A)	Connection
		1 C = cable 200mm
		2 C = cable 400mm
		C = cable
		V = screws

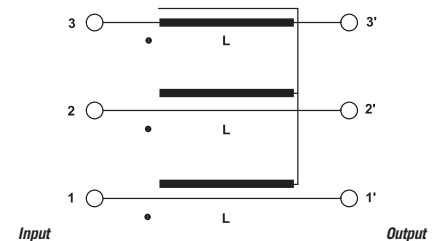
**FIN900.(010 - 280).V**
**ATTENUATION INDICATOR**

**ELECTRIC DIAGRAM**

**TECHNICAL SPECIFICATIONS**

Nominal voltage	0 / 600 Vac
Output frequency	50 – 60 Hz
Rated current	10 TO 280A
Potential test voltage phase to phase	1750 Vdc (2 sec.)
Potential test voltage phase to ground	2150 Vdc (2 sec.)
IP Protection	IP20
Overload capability	4 x Rated current (Switch ON) 2 x In 10 seconds 1.5 In for 10 minutes
Climatic class	-40 / +85° C
MTBF at 40°C	250.000 Hrs

### ELECTRICAL CHARACTERISTICS

FIN900	Rated Current 40°C	Rated Current 50°C	Power Loss (W)
.010.1C	10	9	6
.016.1C	16	14	6
.030.1C	3	26	6

FIN900	Rated Current 40°C	Rated Current 50°C	Power Loss (W)
.010.1C	10	9	6
.016.1C	16	14	6
.030.1C	3	26	6

FIN900	Rated Current 40°C	Rated Current 50°C	Power Loss (W)
.010.V	10	9	6
.016.V	16	14	10
.030.V	30	26	15
.050.V	50	45	23
.080.V	80	72	28
.100.V	100	90	45
.150.V	150	135	75
.200.V	200	180	83
.280.V	280	252	96

### CONNECTIONS

LINE		PE	
d (mm)	Torque (Nm)	d1 (mm)	Torque (Nm)
-	-	M12	20
-	-	M12	20
-	-	M12	20

LINE		PE	
d (mm)	Torque (Nm)	d1 (mm)	Torque (Nm)
-	-	-	-
-	-	-	-
-	-	-	-

LINE		PE	
d (mm)	Torque (Nm)	d1 (mm)	Torque (Nm)
M4	1.2	M4	1.2
M5	4	M4	1.2
M5	4	M4	1.2
M6	6	M5	4
M6	6	M5	4
M8	14	M8	14
M8	14	M8	14
M10	18	M10	18
M12	18	M10	18

### TYPICAL MEASUREMENT

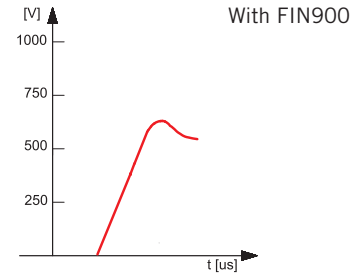
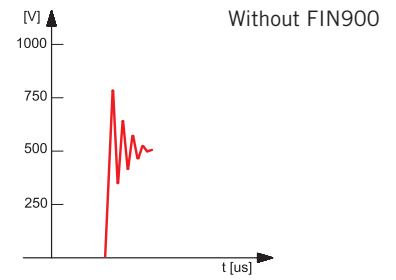

Example of measurement in a typical application using a servo drive

### MECHANICAL DIMENSIONS mm

FIN900	A	B	d	V	d1	H	Weight Kg.	Case
.010.1C	60	65	2	12	M12	200	0.5	1C
.016.1C	60	65	2	12	M12	200	0.5	1C
.030.1C	60	65	2	12	M12	200	0.55	1C

### CASE 1C

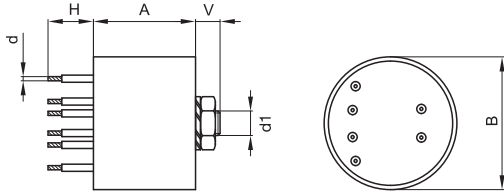

### ASSEMBLY CONNECTION "1C"

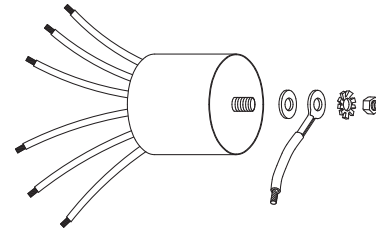

FIN900	A	B	d	V	F	H	I	L	N	Weight Kg.	Case
.010.C	42	65	2	200	4.2	120	96	110	51	0.7	C
.016.C	42	65	2	200	4.2	120	96	110	51	0.7	C
.030.C	42	65	2	200	4.2	120	96	110	51	0.75	C

### CASE C

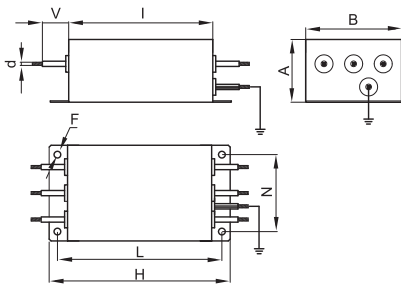

### ASSEMBLY CONNECTION "C"

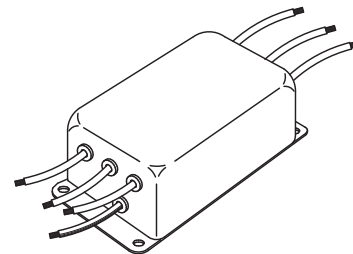

## MECHANICAL DIMENSIONS mm

FIN900	A	B	C	d	d1	V	F	H	I	L	N	P	S	Weight Kg.	Case
.010.V	58	86	44	M4	M4	14	4.5	186	160	176	30	40	38	2	1
.016.V	58	86	44	M5	M4	14	4.5	186	160	176	30	40	38	2	1
.030.V	58	86	44	M5	M4	14	4.5	186	160	176	30	40	38	2	1
.050.V	58	86	44	M6	M5	14	4.5	186	160	176	30	40	38	2	1
.080.V	90	100	46	M6	M5	28	4.5	246	220	235	35	70	64	3	2
.100.V	9	185	84	M8	M8	25	6.5	356	320	340	77.5	70	69	5	3
.150.V	90	220	120	M8	M8	29	6.5	356	320	340	95	70	60	7	4
.200.V	90	220	120	M10	M10	29	6.5	356	320	340	95	70	60	7.5	4
.280.V	90	220	120	M12	M10	29	6.5	356	320	340	95	70	60	8	4

### CASE 1, 2

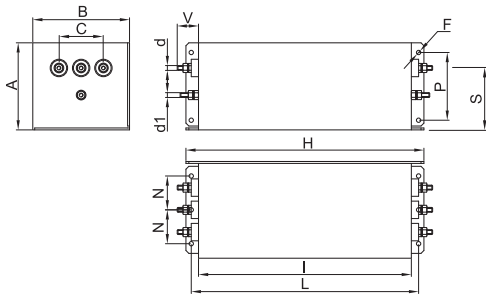

### ASSEMBLY CONNECTION "V"

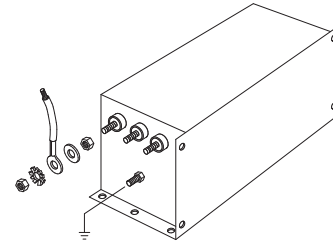

### CASE 3, 4

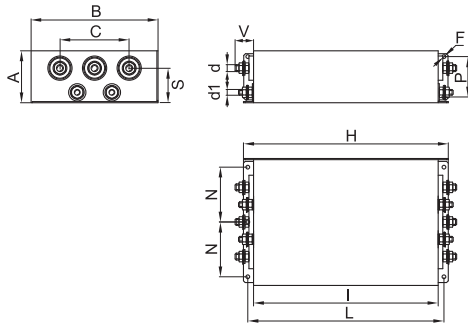

### ASSEMBLY CONNECTION "V"

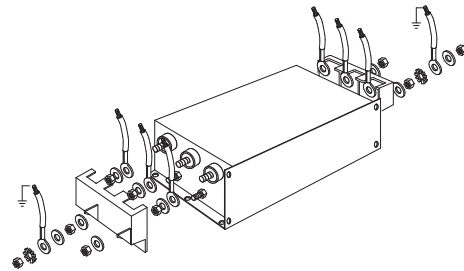



## Common mode choke with very high attenuation for reducing dV/dt

Datasheet 3/2017

**APPROVALS:**

**FIN930.(006 - 200).M**

**FEATURES**

- Rated current from 6 to 200A
- Increases motor life
- Protects against voltage spikes to the motor

**BENEFITS**

- 5 Year warranty
- Safety terminal block connectors
- Helps comply with the conducted and radiated emission requirements of the European Standard

**MARKETS**

- Motors controlled by drives
- Pumps
- Conveyors
- Spindle motors closed loop

**ORDERING CODE**

FIN930 .055 .M  
 Model Current (A) Connection  
 M = Terminal block

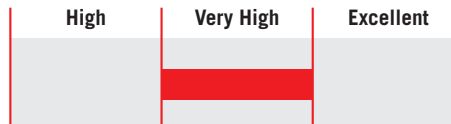
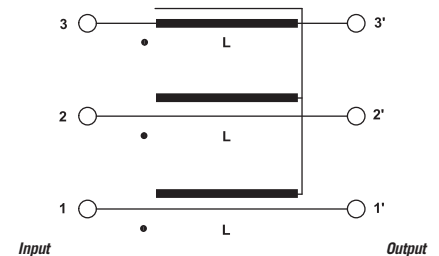
**ATTENUATION INDICATOR**

**ELECTRIC DIAGRAM**

**TECHNICAL SPECIFICATIONS**

Nominal voltage	0 / 600 Vac
Output frequency	50 – 60 Hz
Rated current	6 to 200A
Potential test voltage phase to phase	2400 Vdc (2 sec.)
Potential test voltage phase to ground	3200 Vdc (2 sec.)
IP Protection	IP20
Overload capability	4 x Rated current (Switch ON) 2 x In 10 seconds 1.5 In for 10 minutes
Climatic class	-40 / +85° C
MTBF at 40°C	250.000 Hrs

### ELECTRICAL CHARACTERISTICS

FIN930	Rated Current 40°C	Rated Current 50°C	Power Loss (W)
.006.M	8	6	3
.012.M	14	12	3
.016.M	18	16	4
.025.M	28	25	4
.032.M	35	32	5
.042.M	50	42	7
.055.M	63	55	8
.070.M	80	70	13
.080.M	90	80	13
.100.M	110	100	15
.115.M	130	115	22
.150.M	175	150	25
.200.M	230	200	28

### CONNECTIONS

LINE			PE	
Solid Cable (mm <sup>2</sup> )	Stranded Cable (mm <sup>2</sup> )	Terminal Torque (Nm)	d (mm)	Torque (Nm)
0.2 - 10	0.2 - 6	1.2	M6	1.2
0.2 - 10	0.2 - 6	1.2	M6	1.2
0.2 - 10	0.2 - 6	1.2	M6	1.2
0.2 - 10	0.2 - 6	1.2	M6	1.2
0.2 - 10	0.2 - 6	1.2	M6	1.2
0.5 - 16	0.5 - 10	1.8	M6	1.8
0.5 - 16	0.5 - 10	1.8	M6	1.8
4 - 25	6 - 35	4.5	M10	4.5
4 - 25	6 - 35	4.5	M10	4.5
10 - 50	10 - 50	4	M10	4
10 - 50	10 - 50	4	M10	4
35 - 95	35 - 95	20	M10	20
35 - 95	35 - 95	20	M10	20

### TYPICAL MEASUREMENT

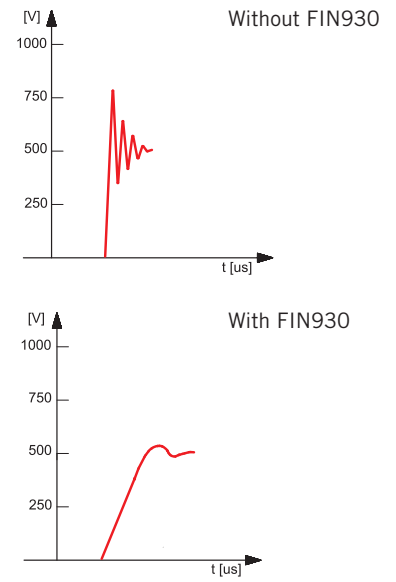

Example of measurement in a typical application using a servo drive

### MECHANICAL DIMENSIONS mm

FIN930	A	B	V	V1	F	H	I	L	N	d	Weight Kg.	Case
.006.M	140	50	19	15	6	226	200	7	28	M6	1.7	1
.012.M	140	50	19	15	6	226	200	7	28	M6	1.7	1
.016.M	177	60	19	15	6	267	237	8	34	M6	1.7	1
.025.M	177	60	19	15	6	267	237	8	34	M6	2.3	1
.032.M	177	60	19	15	6	267	237	8	34	M6	2.3	1
.042.M	177	70	19	25	6	295	265	8	44	M6	3.4	1
.055.M	177	70	19	33	6	295	265	8	44	M6	3.5	1
.070.M	205	80	28	38	8	390	340	12	53	M10	6	1
.080.M	205	80	28	38	8	390	340	12	53	M10	6	1
.100.M	205	80	28	43	8	390	340	12	53	M10	7.1	1
.115.M	205	80	28	43	8	390	340	12	53	M10	7.1	1
.150.M	220	105	28	50	8	420	370	12	78	M10	8.5	1
.200.M	220	105	28	50	8	420	370	12	78	M10	8.5	1

### CASE 1

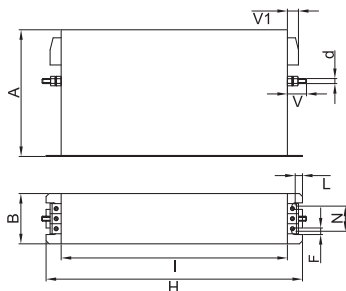

### ASSEMBLY CONNECTION "M"

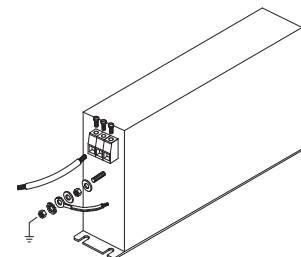



## Differential mode choke with very high attenuation to reduce dV/dt

Datasheet 3/2017

**APPROVALS:**

**FIN950U.(008 - 300).M**

**FEATURES**

- Rated current from 8 to 300A
- Increases motor life
- Protects against voltage spikes to the motor

**BENEFITS**

- Terminal blocks up to 200A
- Low power loss
- Available in open frame or enclosure

**MARKETS**

- Motors controlled by drives
- Pumps
- Conveyers

**ORDERING CODE**

FIN 950U .008 .M  
 Model Current (A) Connection  
 M = Terminal block

Models available with current ratings up to 3000A

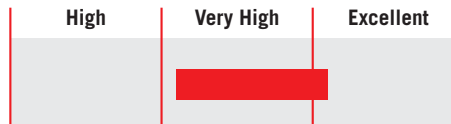
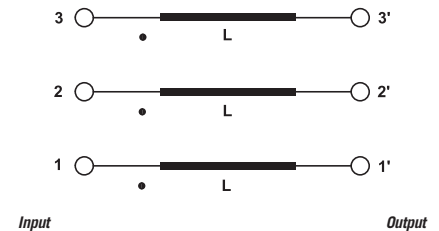
**ATTENUATION INDICATOR**

**ELECTRIC DIAGRAM**

**TECHNICAL SPECIFICATIONS**

Nominal voltage	0 / 600 Vac
Output frequency	0 - 100 Hz
Rated current	8 to 300A
Insulation class	H
IP Protection	IP20 up to 200A IP00 over 200A
Overload capability	4 x Rated current (Switch ON) 2 x In 10 seconds 1.5 In for 10 minutes
Climatic class	-40 / +85° C
MTBF at 40°C	250.000 Hrs



### ELECTRICAL CHARACTERISTICS

FIN950U	Rated Current 40°C	Rated Current 50°C	Power Loss (W)
.008.M20	8	6	23
.012.M12	12	10	30
.024.M070	24	21	36
.050.M038	50	45	61
.090.M019	90	81	73
.150.M013	150	135	120
.200.M0080	200	180	150
.300.M0053	300	260	225

### CONNECTIONS

LINE			PE
Solid Cable (mm <sup>2</sup> )	Stranded Cable (mm <sup>2</sup> )	Terminal Block Torque (Nm)	Torque (Nm)
0.2 - 10	0.2 - 6	1.2	1.2
0.2 - 10	0.2 - 6	1.2	1.2
0.2 - 10	0.2 - 6	1.2	1.2
0.5 - 10	0.5 - 10	1.8	1.8
10 - 50	10 - 50	4.0	4.0
10 - 50	10 - 50	4.0	4.0
35 - 95	35 - 95	20	20
70 - 240	70 - 240	30	30

### TYPICAL MEASUREMENT

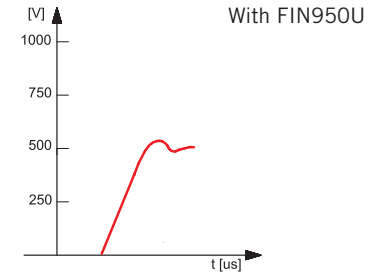
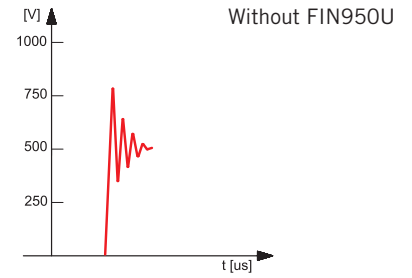

Example of measurement in a typical application using a servo drive

### MECHANICAL DIMENSIONS mm

FIN950U	A	B	C	D	F	H	Weight Kg.	Case
.008.M20	150	125	100	55	7	250	2	1
.012.M12	150	125	100	55	7	250	3	1
.024.M070	150	125	100	55	7	250	4	1
.050.M038	180	150	110	90	7	280	5	1
.090.M019	180	150	110	90	7	280	18	1
.150.M013	240	200	190	95	10	310	20	1
.200.M0080	240	200	190	95	10	310	26	1
.300.M0053	300	260	170	110	10	310	40	1

### CASE 1

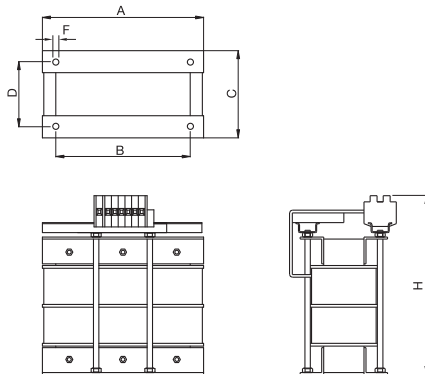



## High frequency differential choke with excellent attenuation to reduce dV/dt

Datasheet 3/2017

**APPROVALS:**
**SCCR** by UL508A

**FIN5955.(003 - 020).M**
**FEATURES**

- Rated current from 3 to 20A
- Increases motor life
- Protects against voltage spikes to the motor
- Low power loss up to 250 Hz frequency output

**BENEFITS**

- 2 Year warranty
- Safety terminal block connectors
- Very compact case

**MARKETS**

- High speed motors up to 250 Hz
- AC motors controlled by VFDs
- Woodworking equipment
- Spindle motors closed loop

**ORDERING CODE**

FIN955	.020	.M
Model	Current (A)	Connection
		M = Terminal block

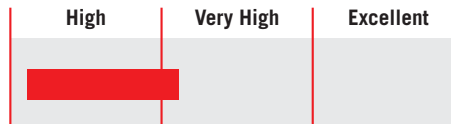
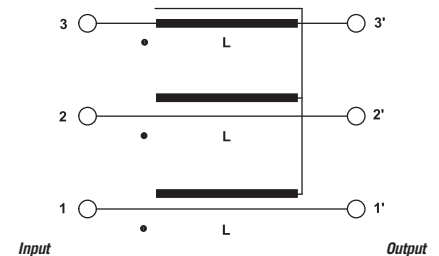
**ATTENUATION INDICATOR**

**ELECTRIC DIAGRAM**

**TECHNICAL SPECIFICATIONS**

Nominal voltage	0 / 600 Vac
Output frequency	0 – 250 Hz
Rated current	3 to 20A
Potential test voltage phase to phase	2400 Vdc (2 sec.)
Potential test voltage phase to ground	3200 Vdc (2 sec.)
IP Protection	IP20
Overload capability	4 x Rated current (Switch ON) 2 x In 10 seconds 1.5 In for 10 minutes
Climatic class	-40 / +85° C
MTBF at 40°C	250.000 Hrs.

### ELECTRICAL CHARACTERISTICS

FIN5955	Rated Current 40°C	Rated Current 50°C	Power Loss (W)
.003.M	3	2	2.2
.006.M	6	5	2.4
.010.M	10	8	2.7
.020.M	20	17	3

### CONNECTIONS

LINE			PE	
Solid Cable (mm <sup>2</sup> )	Stranded Cable (mm <sup>2</sup> )	Terminal Torque (Nm)	V (mm)	Torque (Nm)
0.2 - 10	0.2 - 6	1.2	M4	1.2
0.2 - 10	0.2 - 6	1.2	M4	1.2
0.2 - 10	0.2 - 6	1.2	M4	1.2
0.2 - 10	0.2 - 6	1.2	M4	1.2

### TYPICAL MEASUREMENT

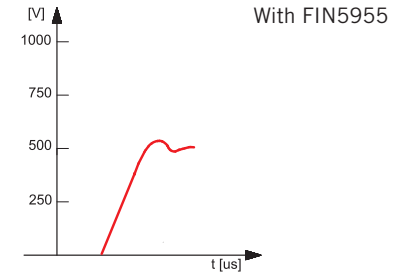
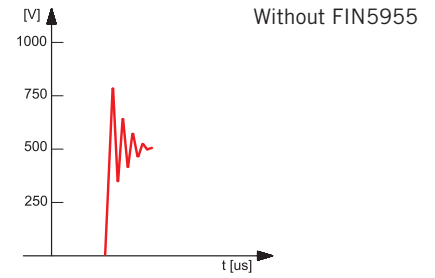

Example of measurement in a typical application using a servo drive

### MECHANICAL DIMENSIONS mm

FIN5955	A	B	C	D	H	N	I	V	Weight Kg.	Case
.003.M	60	101	125	113	51	11	4x17	M4	0.40	1
.006.M	60	101	125	113	51	11	4x17	M4	0.40	1
.010.M	60	101	125	113	51	11	4x17	M4	0.45	1
.020.M	60	101	125	113	51	11	4x17	M4	0.45	1

### CASE 1

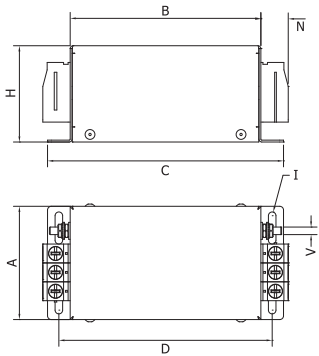

### ASSEMBLY CONNECTION "M"

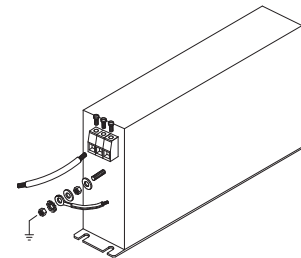



## High frequency differential choke with excellent attenuation to reduce dV/dt

Datasheet 3/2017

**APPROVALS:**

**FIN958.(012 - 110).M**
**FEATURES**

- Rated current from 12 to 110A
- Protects against voltage spikes to the motor
- Low power loss up to 1 kHz frequency output

**BENEFITS**

- 2 Year warranty
- Safety terminal block connectors

**MARKETS**

- High speed motors
- High speed pumps
- Woodworking equipment
- Spindle motors closed loop

**ORDERING CODE**

FIN958	.012	.M
Model	Current (A)	Connection
		M = Terminal block

**ATTENUATION INDICATOR**

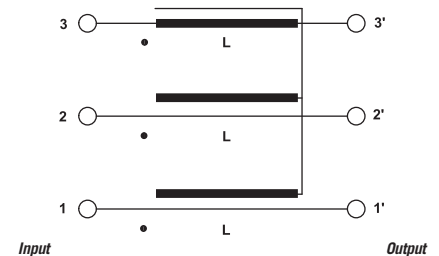
**ELECTRIC DIAGRAM**

**TECHNICAL SPECIFICATIONS**

Nominal voltage	0 / 600 Vac
Output frequency	0 - 1000 Hz
Rated current	12 to 110A
Potential test voltage phase to phase	2400 Vdc (2 sec.)
Potential test voltage phase to ground	3200 Vdc (2 sec.)
IP Protection	IP20
Overload capability	4 x Rated current (Switch ON) 2 x In 10 seconds 1.5 In for 10 minutes
Climatic class	-40 / +85° C
MTBF at 40°C	250.000 Hrs

### ELECTRICAL CHARACTERISTICS

FIN958	Rated Current 40°C	Rated Current 50°C	Power Loss (W)
.012.M	12	10	3.4
.020.M	20	18	4.4
.025.M	25	23	4.8
.032.M	32	28	5.3
.042.M	42	38	7
.060.M	60	54	11
.075.M	75	67	12
.090.M	90	81	12.7
.110.M	110	100	13

### CONNECTIONS

LINE			PE	
Solid Cable (mm <sup>2</sup> )	Stranded Cable (mm <sup>2</sup> )	Terminal Torque (Nm)	d (mm)	Torque (Nm)
0.2 - 10	0.2 - 6	1.2	M6	1.2
0.2 - 10	0.2 - 6	1.2	M6	1.2
0.2 - 10	0.2 - 6	1.2	M6	1.2
0.2 - 10	0.2 - 6	1.2	M6	1.2
0.2 - 10	0.2 - 6	1.2	M6	1.2
6 - 35	4 - 25	4.5	M6	6
6 - 35	4 - 25	4.5	M6	6
10 - 50	10 - 50	4.0	M10	6
35 - 95	35 - 95	20.0	M10	6

### TYPICAL MEASUREMENT

Without FIN958

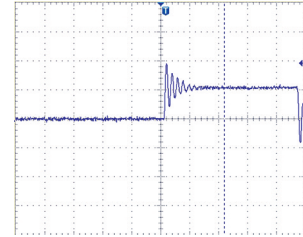

With FIN958

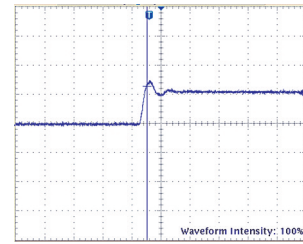

Example of measurement in a typical application using a servo drive

### MECHANICAL DIMENSIONS mm

FIN958	A	B	V	V1	F	H	I	L	N	d	Weight Kg.	Case
.012.M	100	90	22	16	5.4	250	220	7.5	60	M6	1.9	1
.020.M	100	90	22	16	5.4	250	220	7.5	60	M6	1.9	1
.025.M	100	90	22	16	5.4	250	220	7.5	60	M6	1.9	1
.032.M	100	90	22	16	5.4	250	220	7.5	60	M6	2.0	1
.042.M	100	90	22	35	5.4	250	220	7.5	60	M6	2.5	2
.060.M	135	85	22	39	6.5	270	240	7.5	60	M6	3.8	3
.075.M	135	85	22	39	6.5	270	240	7.5	60	M6	4.5	3
.090.M	155	90	24	43	6.5	270	240	7.5	65	M10	6.0	3
.110.M	170	125	26	51	6.5	380	350	7.5	102	M10	8.5	4

### CASE 1, 2, 3, 4

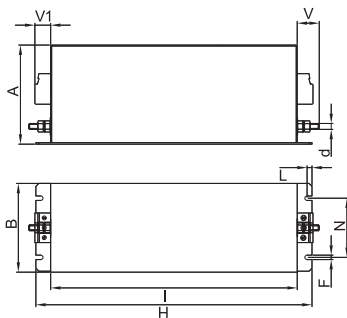

### ASSEMBLY CONNECTION "M"

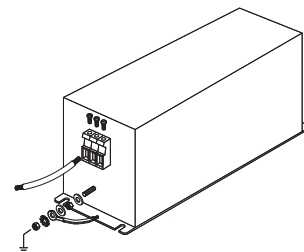



## High frequency differential choke with excellent attenuation to reduce dV/dt

Datasheet 3/2017

### APPROVALS:



UL508  
CSA C22.2

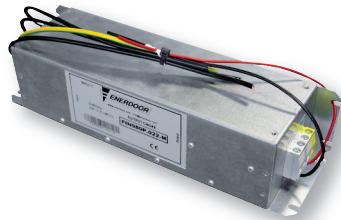

FIN5980P.(009 - 022).M

### FEATURES

- Rated current from 9 to 22A
- Increases motor life
- Protects against voltage spikes to the motor

### BENEFITS

- Overvoltage spikes regenerate into the DC bus
- Safety terminal block connectors
- Low power loss up to 1.5 kHz frequency output

### MARKETS

- Motors controlled by drive
- Spindle motors
- Closed loop motor applications

### ORDERING CODE

FIN 5980P .012 .M  
 Model Current (A) Connection  
 M = Terminal block

### ATTENUATION INDICATOR

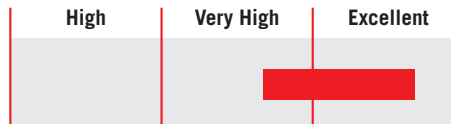

### ELECTRIC DIAGRAM

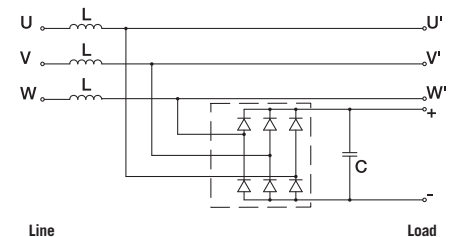

### TECHNICAL SPECIFICATIONS

Nominal voltage	0 / 480 Vac
Output frequency	0 – 1500 Hz
Rated current	9 to 22A
Potential test voltage phase to phase	1200 Vdc (2 sec.)
Potential test voltage phase to ground	3200 Vdc (2 sec.)
IP Protection	IP20
Overload capability	4 x Rated current (Switch ON) 2 x In 10 seconds 1.5 In for 10 minutes
Climatic class	-40 / +85° C
MTBF at 40°C	250.000 Hrs.

### ELECTRICAL CHARACTERISTICS

FIN5980P	Rated Current 40°C	Rated Current 50°C	Power Loss at 50 Hz (1000 Hz)
.009.M	12	10	1.2 (2.7)
.022.M	30	25	1.8 (4.7)

### CONNECTIONS

Solid Cable (mm <sup>2</sup> )	Stranded Cable (mm <sup>2</sup> )	Terminal Block Torque (Nm)	LINE	PE
			Torque (Nm)	Torque (Nm)
0.5 - 16	0.5 - 10	1.8	1.8	1.8
0.5 - 16	0.5 - 10	1.8	1.8	1.8

### MECHANICAL DIMENSIONS mm

FIN5980P	A	B	C	D	E	F	H	I	L1	L2	N	Weight Kg.	Case
.009.M	60	295	345	330	220	280	60	5	300	300	11	2.2	1
.022.M	100	295	34	330	76	280	100	5	300	300	11	3	2

#### CASE 1

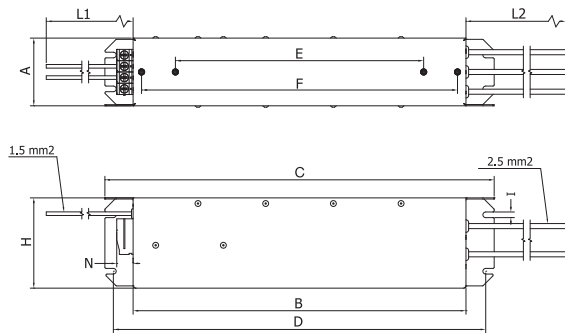

#### CASE 2

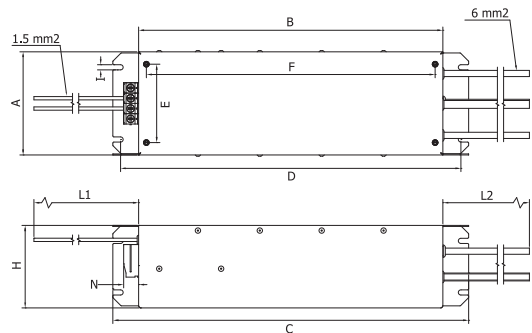



## High frequency differential choke with excellent attenuation to reduce dV/dt

Datasheet 3/2017

**APPROVALS:**

 UL508  
CSA C22.2

**FIN5983.(012 - 060).M**
**FEATURES**

- Rated current from 12 to 60A
- Increases motor life
- Protects against voltage spikes to the motor

**BENEFITS**

- Safety terminal block connectors
- Low power loss up to 1 kHz frequency output

**MARKETS**

- Motors controlled by drives
- Woodworking equipment
- Closed loop motor applications

**ORDERING CODE**

FIN 5983	.012	.M
Model	Current (A)	Connection
		M = Terminal block

**ATTENUATION INDICATOR**

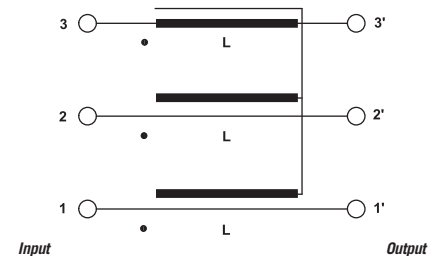
**ELECTRIC DIAGRAM**

**TECHNICAL SPECIFICATIONS**

Nominal voltage	0 / 600 Vac
Output frequency	0 – 1000 Hz
Rated current	12 to 60A
Potential test voltage phase to phase	2400 Vdc (2 sec.)
Potential test voltage phase to ground	3200 Vdc (2 sec.)
IP Protection	IP20
Overload capability	4 x Rated current (Switch ON) 2 x In 10 seconds 1.5 In for 10 minutes
Climatic class	-40 / +85° C
MTBF at 40°C	250.000 Hrs.



### ELECTRICAL CHARACTERISTICS

FIN5983	Rated Current 40°C	Rated Current 50°C	Power Loss (W)
.012.M	12	10	1.2 (2.7)
.030.M	30	25	1.8 (4.7)
.040.M	45	37	3 (7)
.060.M	60	50	8 (16.8)

### CONNECTIONS

LINE			PE
Solid Cable (mm <sup>2</sup> )	Stranded Cable (mm <sup>2</sup> )	Terminal Torque (Nm)	Torque (Nm)
0.5 - 16	0.5 - 10	1.8	1.8
0.5 - 16	0.5 - 10	1.8	1.8
0.5 - 16	0.5 - 10	1.8	1.8
4 - 25	6 - 35	4.5	4.5

### TYPICAL MEASUREMENT

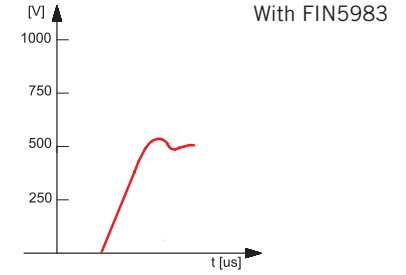
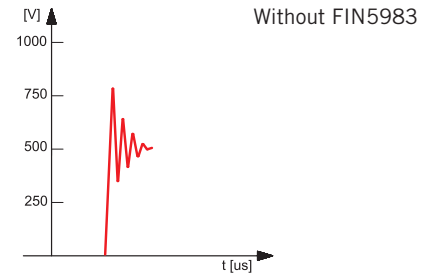

Example of measurement in a typical application using a servo drive

### MECHANICAL DIMENSIONS mm

FIN5983	A	B	C	D	E1	E2	F	G	H	J	L	I	N	Weight Kg.	Case
.012.M	140	295	345	330	14	76	280	80	80	50	300	5	33	2.2	1
.030.M	140	295	345	330	14	76	280	80	80	50	300	5	33	2.5	1
.040.M	200	295	345	330	-	160	280	120	80	50	300	5	38	3.2	1
.060.M	200	295	345	330	-	160	280	120	80	50	300	5	38	4	1

### CASE 1

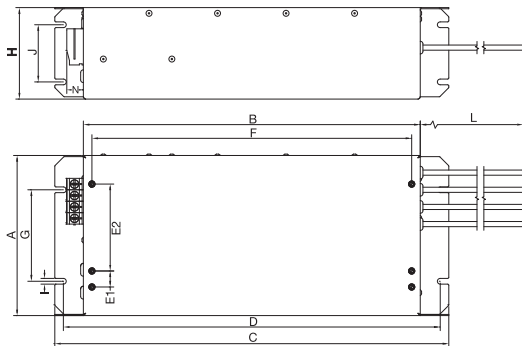

### ASSEMBLY CONNECTION "M"

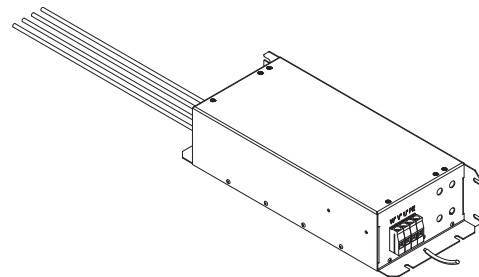



## High frequency differential mode choke with excellent attenuation for high speed motors

Datasheet 3/2017

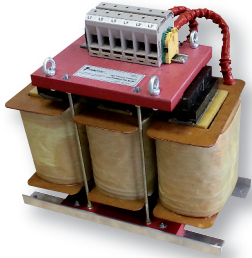
**APPROVALS:**

**FIN960F.(010 - 1000).M**
**FEATURES**

- Rated current from 10 to 1000A
- Increases motor life
- Protects against voltage spikes to the motor
- Customizable per motor specifics to optimize the system

**BENEFITS**

- Low power loss with frequency output up to 10 kHz
- No ventilation required
- Excellent performance versus frequency and current
- Available in open frame or enclosure

**MARKETS**

- High speed motors
- CNC Machines
- Woodworking machines

**ORDERING CODE**

FIN960F	.050	.M	010
Model	Current (A)	Connection	Inductance value (L)
		M = Terminal block	

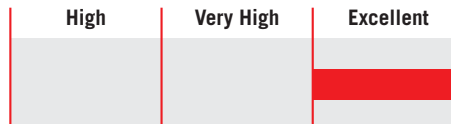
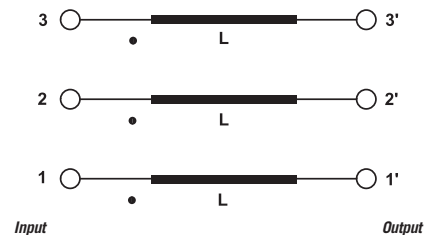
**ATTENUATION INDICATOR**

**ELECTRIC DIAGRAM**

**TECHNICAL SPECIFICATIONS**

Nominal voltage	0 / 750 Vac
Output frequency	0 – 60 Hz
Rated current	10 to 1000A
Potential test voltage phase to phase	2400 Vdc (2 sec.)
Potential test voltage phase to ground	3200 Vdc (2 sec.)
IP Protection	IP20
Overload capability	4 x Rated current (Switch ON) 2 x In 10 seconds 1.5 In for 10 minutes
Climatic class	-40 / +85° C
MTBF at 40°C	250.000 Hrs

### ELECTRICAL CHARACTERISTICS

FIN960F	Rated Current 40°C	Rated Current 50°C	Power Loss (W)
.050.M010	50	75	70
.110.M010	110	150	110
.160.M010	160	200	150
.095.M020	95	130	90
.130.M025	130	160	115
.160.M025	160	180	170
.090.M030	90	120	60
.050.M040	50	75	80
.110.M040	110	150	280
.200.M040	200	240	580
.085.M060	85	120	280
.135.M060	135	165	300
.170.M060	170	205	520
.120.M100	120	145	305
.200.M100	200	240	820

### CONNECTIONS

Solid Cable (mm <sup>2</sup> )	LINE		Terminal Block Torque (Nm)	PE Torque (Nm)
	Stranded Cable (mm <sup>2</sup> )			
2.5 - 50	2.5 - 35		5	5
10 - 70	10 - 50		6	6
10 - 95	10 - 50		10	10
10 - 70	10 - 50		6	6
10 - 95	10 - 70		10	10
10 - 95	10 - 70		10	10
10 - 70	10 - 50		6	6
2.5 - 50	2.5 - 35		5	5
10 - 70	10 - 50		6	6
16 - 150	16 - 95		20	20
10 - 70	10 - 50		6	6
10 - 95	10 - 70		10	10
10 - 95	10 - 70		10	10
10 - 70	10 - 50		6	6
16 - 250	16 - 95		20	20

Custom nominal current and inductance value combinations are available to accommodate specific motor characteristics and working cycles.

### MECHANICAL DIMENSIONS mm

FIN960F	A	B	C	D	E	F	G	Weight Kg.	Case
.050.M010	230	250	80	100	7	270	120	6	1
.110.M010	240	260	110	140	7	270	150	18	2
.160.M010	370	400	170	230	12	350	250	37	3
.095.M020	240	260	110	140	7	270	150	20	2
.160.M025	500	540	200	260	12	500	300	75	5
.130.M030	500	540	200	260	12	500	300	65	5
.050.M040	280	300	140	160	8	280	180	19	6
.110.M040	500	540	200	260	12	500	300	65	5
.200.M040	500	540	200	260	12	500	300	120	5
.085.M060	500	540	200	260	12	500	300	65	5
.135.M060	500	540	200	260	12	500	300	88	5
.170.M060	500	540	200	260	12	500	300	105	5
.120.M100	500	540	200	260	12	500	300	95	5
.200.M100	660	700	320	390	12	600	410	200	7

#### CASE 1, 2, 6

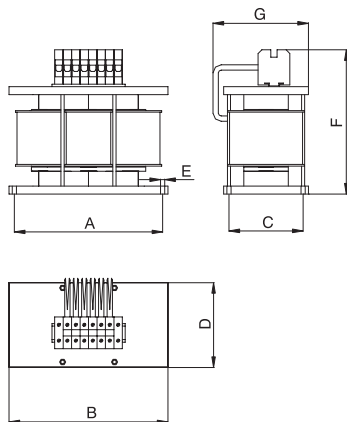

#### CASE 3, 4, 5, 7

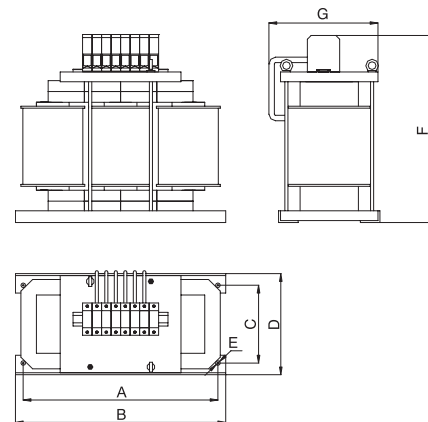



## Sine wave filter with excellent attenuation for variable frequency drive applications

Datasheet 3/2017

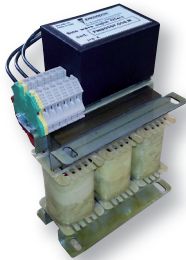
**APPROVALS:**

**FIN905SF.(005 - 045).M**
**FEATURES**

- Rated current from 5 to 880A
- Very compact size
- Available in Nema 1 or Nema 3R enclosure

**BENEFITS**

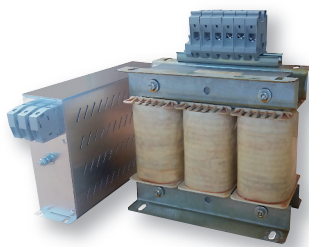
- Low power loss with frequency output up to 10 kHz
- No ventilation required
- Excellent performance versus frequency and current
- Available in open frame or enclosure



**FIN905SF.(060 - 180).M**
**MARKETS**

- Long cable applications - 2.500m
- Process plants
- Water treatment
- Agriculture
- Variable frequency drives

**ORDERING CODE**

FIN905SF	.100	.M	-N1
Model	Current (A)	Connection	Enclosure
		M = Terminal	N1 = Nema 1 (IP20)
		V = Screws	N3R = Nema 3R (IP54)
		B = Bus bar	

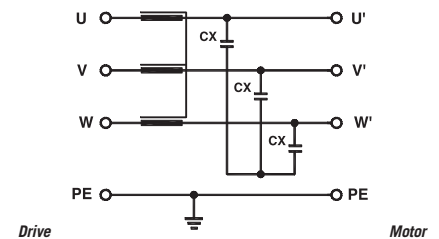
**ATTENUATION INDICATOR**

**ELECTRIC DIAGRAM**

**FIN905SF.(260 - 410).B**
**TECHNICAL SPECIFICATIONS**

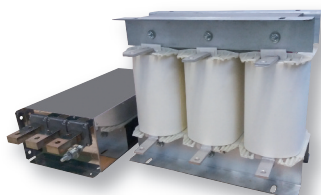
Nominal voltage	0 / 600 Vac
Output frequency	0 – 60 Hz
Rated current	5 to 880A
VFD carrier frequency	From 4 KHz to 12 KHz, see table
Ambient temperature	70°C
Altitude	1000 m
Relative humidity	<95% no condensation
Overload capability	4 x Rated Current (Switch ON) 2 x In 10 seconds 1.5 x In 10 minutes
IP Protection	IP20 up to 180A IP00 over 260A
Optional	Enclosure, fan

**FIN905SF.(480 - 880).B**

### ELECTRICAL CHARACTERISTICS

FIN905SF	Rated Current 40°C	Rated Current 50°C	Min. Switch Freq. (kHz)	Power Loss (W)
.005.M	5	4	4	67
.008.M	8	7	4	79
.010.M	10	8	4	88
.016.M	16	14	4	116
.025.M	25	21	4	151
.036.M	36	30	4	175
.048.M	48	39	4	250
.060.M	60	50	4	282
.075.M	75	60	4	340
.115.M	115	95	4	575
.180.M	180	145	4	695

### CONNECTIONS

Solid Cable (mm <sup>2</sup> )	LINE		Terminal Block Torque (Nm)	PE
	Stranded Cable (mm <sup>2</sup> )			Torque (Nm)
0.2-10	0.2-6		1.2	1.2
0.2-10	0.2-6		1.2	1.2
0.2-10	0.2-6		1.2	1.2
0.2-10	0.2-6		1.2	1.2
0.2-10	0.2-6		1.2	1.2
0.2-10	0.2-6		1.8	1.8
0.2-10	0.2-6		1.8	1.8
6-35	4-25		4.5	4.5
6-35	4-25		4.5	4.5
10-50	10-50		4	4
39-95	35-95		20.0	20.0

### TYPICAL MEASUREMENT

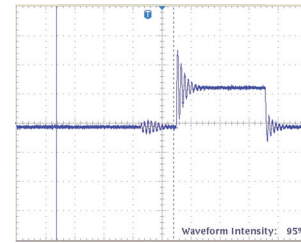

Standard waveform measured when the motor is controlled by VFD drive.

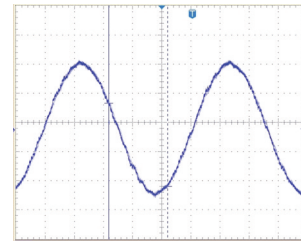

Standard waveform measured when Enerdoor sine wave filter is installed on motor controlled by VFD drive.

FIN905SF	Rated Current 40°C	Rated Current 50°C	Min. Switch Freq. (kHz)	Power Loss (W)
.260.B	260	205	4	895
.320.M	320	290	4	950
.410.M	410	350	6	1170
.480.M	480	420	6	1390
.660.M	660	580	6	2050
.750.M	750	650	6	2900
.880.M	880	750	6	3450

Solid Cable (mm <sup>2</sup> )	LINE		Terminal Block Torque (Nm)	PE
	Stranded Cable (mm <sup>2</sup> )			Torque (Nm)
M8	14		M10	18
M8	14		M10	18
M8	14		M10	18
M12	20		M10	18
M12	20		M10	18
M12	20		M10	18
M12	20		M10	18

**MECHANICAL DIMENSIONS mm**

FIN905SF	A	B	C	D	E	F	G	H Ø	Weight Kg.	Case
<b>005.M</b>	180	90	156	150	60	116	235	8	2	1
<b>008.M</b>	180	90	156	150	60	116	235	8	2	1
<b>010.M</b>	180	90	156	150	60	116	235	8	3	1
<b>016.M</b>	240	130	210	210	95	165	290	8	3	1
<b>025.M</b>	240	130	210	210	95	165	290	8	3	1
<b>036.M</b>	240	130	210 <td 210	95	165	290	8	5	2	
<b>.048.M</b>	240	130	210	210	95	165	290	8	5	2

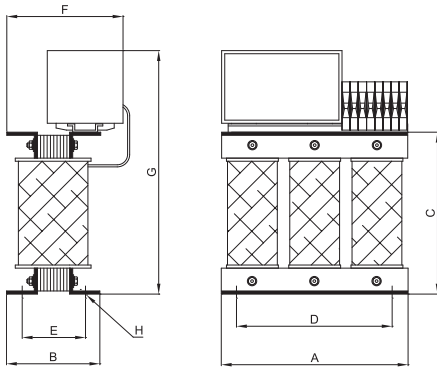
**CASE 1, 2**

FIN905SF	A	B	C	D	E	F	G	H	I	L	N	P	V	d	Weight Kg.	Case
<b>.060.M</b>	300	165	260	260	110	8	5	332	260	100	120	135	180	M5	3	3
<b>.075.M</b>	360	174	305	260	120	8	5	377	293	100	120	135	180	M5	3	3
<b>.115.M</b>	360	203	310	260	145	8	5	400	389	130	205	220	260	M5	4	4
<b>.180.M</b>	360	230	310	260	165	8	5	400	389	130	205	220	260	M5	4	4

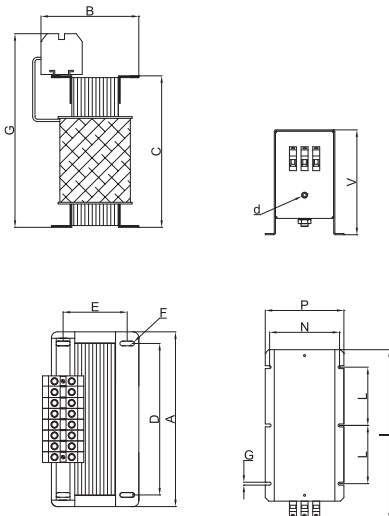
**CASE 3, 4**

**MECHANICAL DIMENSIONS mm**

FIN905SF	A	B	C	D	E	F	G	H	I	L	N	P	V	d	S	Weight Kg.	Case
<b>.260.B</b>	480	280	410	360	230	8	30	5	400	130	290	305	260	M5	-	132	5
<b>.320.B</b>	480	300	410	360	230	8	40	5	400	130	290	305	260	M5	-	163	5
<b>.410.B</b>	480	340	410	360	230	10	60	5	400	130	290	305	260	M5	-	188	5
<b>.480.B</b>	480	360	410	360	230	10	60	5	660	620	245	292	260	M5	25x10	208	6
<b>.660.B</b>	600	370	510	380	240	10	60	5	660	620	245	292	260	M5	25x10	309	6
<b>.750.B</b>	600	390	510	380	240	10	80	5	830	750	245	292	260	M5	25x10	356	6
<b>.880.B</b>	600	370	570	380	240	10	80	5	830	750	245	292	260	M5	25x10	351	6

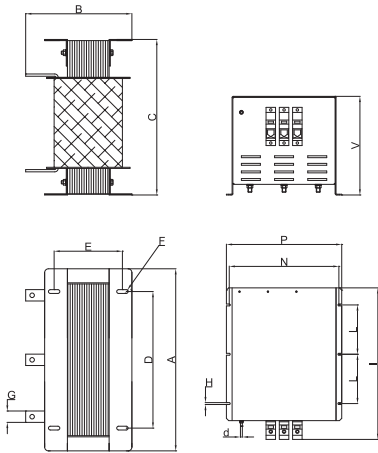
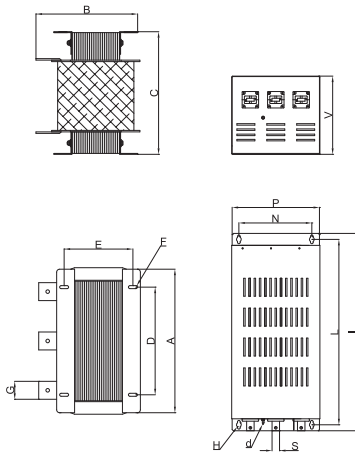
**CASE 5**

**CASE 6**

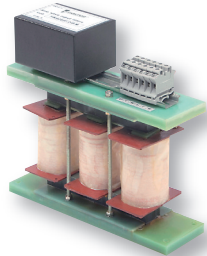

## High frequency sine wave filter with excellent attenuation for variable frequency drive applications

Datasheet 3/2017

**APPROVALS:**

**FIN915SFH.(005 - 048).M**
**FEATURES**

- Rated current from 5 to 1100A
- High performance sine wave output
- Eliminates dV/dt, increases motor life
- Ideal for high speed motor - 75 Hz to 2000 Hz

**BENEFITS**

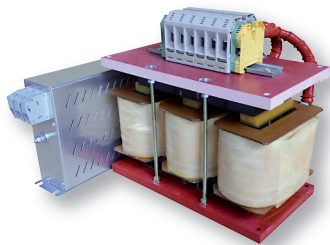
- Terminal blocks up to 880A
- Very compact size
- Available in open frame or enclosure



**FIN915SFH.(060 - 360).M**
**MARKETS**

- Long cable applications - 2.500m
- Process plants
- Water treatment
- Agriculture
- Frequency drives and servo drives >75 Hz

**ORDERING CODE**

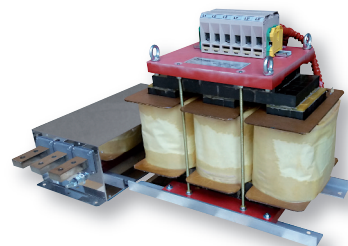
FIN915SF	.100	.M	-N1
Model	Current (A)	Connection	Enclosure
		M = Terminal	N1 = Nema 1
		V = Screws	N3R = Nema 3R
		BC = Bus bar	

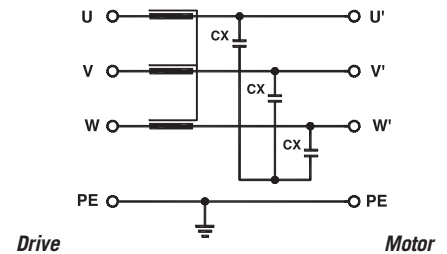
**FIN915SFH.(480 - 1100).M**
**ATTENUATION INDICATOR**

**ELECTRIC DIAGRAM**

**TECHNICAL SPECIFICATIONS**

Nominal voltage	0 / 600 Vac
Output frequency	0 Hz - 2 kHz
Rated current	5 to 1100A
VFD carrier frequency	From 2KHz to 18 KHz see table
Ambient temperature	70°C
Altitude	1000 m
Relative humidity	<95% no condensation
Overload capability	4 x Rated Current (Switch ON) 2 x In 10 seconds 1.5 x In 10 minutes
IP Protection	IP20 up to 360A IP00 over 480A
Optional	Enclosure, fan, finger safe protection





**MECHANICAL DIMENSIONS mm**

FIN915SFH	A	B	C	D	E	F	G	Weight Kg.	Case
.005.M	260	170	252	240	110	8	138	5	1
.010.M	260	170	252	240	110	8	138	6.5	1
.016.M	260	170	252	240	110	8	138	8	1
.025.M	300	240	265	280	140	8	160	12	2
.036.M	300	240	265	280	140	8	160	14	2
.048.M	300	240	265	280	140	8	160	17	2

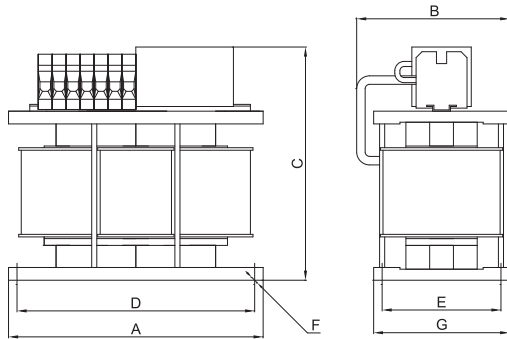
**CASE 1, 2**

FIN915SFH	A	B	C	D	E	F	G	I	L	N	P	R	dØ	V	Weight Kg.	Case
.060.M	400	250	335	370	170	12	260	293	100	120	135	5	5	180	30	3
.075.M	540	360	460	500	200	12	260	293	100	120	135	5	5	180	38	3
.115.M	540	360	460	500	200	12	260	389	130	205	220	5	5	260	63	4
.140.M	540	360	460	500	200	12	260	389	130	205	220	5	5	260	80	4
.180.M	540	320	465	500	200	12	260	389	130	205	220	5	5	260	83	4
.210.M	540	320	465	500	200	12	260	450	150	280	295	5	5	260	88	5
.260.M	540	320	465	500	200	12	260	450	150	280	295	5	5	260	110	5
.360.M	540	320	465	500	200	12	260	450	150	280	295	5	5	260	150	5

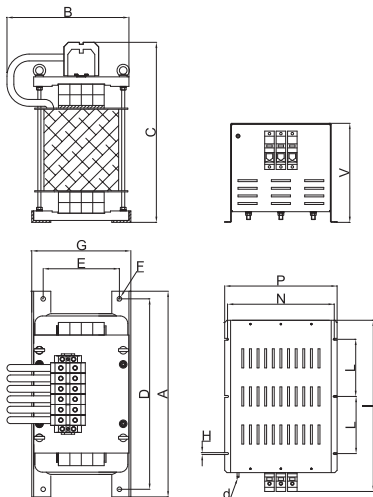
**CASE 3, 4, 5**

**MECHANICAL DIMENSIONS mm**

FIN915SFH	A	B	C	D	E	F	G	I	L	N	P	V	H	d	S	Weight Kg.	Case
<b>.480.M</b>	540	340	475	500	200	12	260	620	660	244	295	262	16	M5	25x10	115	6
<b>.610.M</b>	540	340	475	500	200	12	260	620	660	244	295	262	16	M5	25x10	120	6
<b>.680.M</b>	540	340	475	500	200	12	260	830	790	244	292	292	16	M5	25x10	126	7
<b>.770.M</b>	540	340	475	500	200	12	260	830	790	244	292	292	16	M5	25x10	130	7
<b>.860.M</b>	540	340	475	500	200	12	260	885	830	474	520	292	16	M5	40x20	135	8
<b>.960.M</b>	540	340	475	500	200	12	260	885	830	474	520	292	16	M5	40x20	150	8
<b>.1100.M</b>	540	340	475	500	200	12	260	885	830	474	520	292	16	M5	40x20	200	8

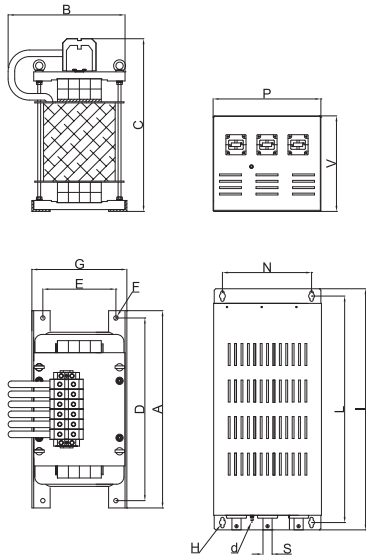
**CASE 6, 7, 8**



## 3-phase plus neutral star point snubber with excellent attenuation to reduce dV/dt

Datasheet 3/2017

**APPROVALS:**

**FIN47SNB.050.1M**
**FEATURES**

- Reduces dV/dt
- Protection of motor winding insulation and bearings
- Remote contact indicator
- Compact dimension due to the parallel installation

**BENEFITS**

- Very low power loss
- Available with remote electronic control
- Easy installation
- Only one model for unlimited HP motors

**MARKETS**

- Large motors
- Spindle motors
- Long cable applications with variable frequency drives or servo drives

**ORDERING CODE**

FIN47SNB	.050	.1M	.A	MSD1
Model	Impedance	Connection	Fan nominal voltage	Electronic control
		1M = 1 motor	A = 24Vdc B = 24Vac	MSD1 at 24Vdc
		2M = 2 motors	C = 110Vac D = 220Vac	MSD2 at 230Vac

**ATTENUATION INDICATOR**

**TECHNICAL SPECIFICATIONS**

Nominal voltage	0 / 600 Vac
Frequency	50 – 1000 Hz
Rated current	Unlimited
Max PWM frequency	5 kHz
Max peak voltage phase to phase	3000V
Max peak voltage phase to ground	3500V
Max power dissipation	250W
Fan dissipation	20W
IP protection	IP20
Climatic class	-40 / +85° C
MTBF at 40°C	250.000 Hrs.

### ELECTRICAL CHARACTERISTICS

FIN47SNB	Nominal Voltage AC (Vac)	Drive Carrier Frequency (KHz)	Power Loss at 100Hz (W)
.050.1M	600	<5	250

### CONNECTIONS

LINE			PE	
Solid Cable (mm <sup>2</sup> )	Stranded Cable (mm <sup>2</sup> )	Terminal Torque (Nm)	d (mm)	Torque (Nm)
10 - 50	10 - 50	4.0	M10	6

### TYPICAL MEASUREMENT

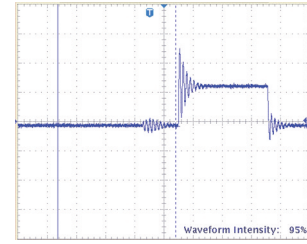

Typical measurement of dV/dt without snubber installed

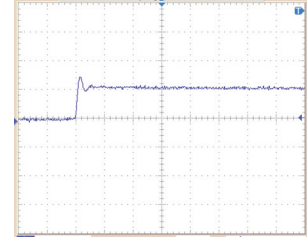

Typical measurement of dV/dt with snubber installed

### MECHANICAL DIMENSIONS mm

FIN47SNB	A	B	C	D	E	F	G	H	I	J	M	L	d	Weight Kg.	Case
.050.1M.X.Y	235	167	246.5	125	110	83	125	8.5	4	13.5	10	15	M10	5	1
.050.2M.X.Y	235	368	376.5	125	110	83	105	5.4	4	8.5	-	15	M10	10	2

### CASE 1

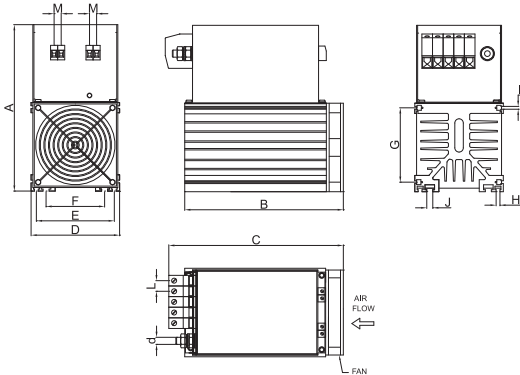

### CASE 2

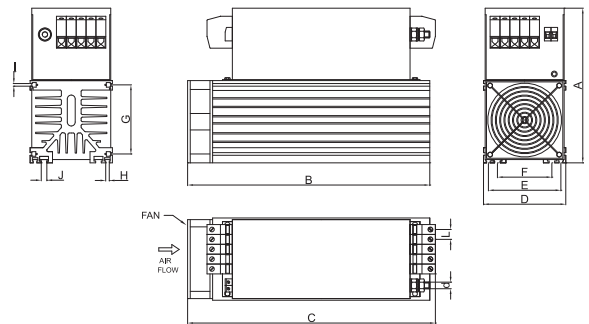



## Star point snubber with excellent attenuation to reduce dV/dt

Datasheet 3/2017

**APPROVALS:**

**FINSTP.(068 - 100).M100**

**FEATURES**

- Reduces dV/dt star point -PE
- Protection of motor winding insulation and bearings
- Remote contact indicator
- Compact dimension due to the parallel installation

**BENEFITS**

- Very low power loss
- Over temperature protection
- Easy installation
- Only one model for unlimited HP motors

**MARKETS**

- Large motors
- Spindle motors
- Long cable applications with variable frequency drives or servo drives

**ORDERING CODE**

FINSTP	.068	.M100	.A
Model	Impedance	-	Fan nominal voltage
			A = 24Vdc
			B = 24Vac
			C = 110Vac
			D = 220Vac

**ATTENUATION INDICATOR**

**TECHNICAL SPECIFICATIONS**

Nominal voltage	0 / 600 Vac
Frequency	50 – 1000 Hz
Rated current	Unlimited
Max PWM frequency	5 kHz
Max peak voltage phase to phase	3000V
Max peak voltage phase to ground	3500V
Max power dissipation	250W
Fan dissipation	20W
IP protection	IP20
Climatic class	-40 / +85° C
MTBF at 40°C	250.000 Hrs.

### ELECTRICAL CHARACTERISTICS

FINSTP	Nominal Voltage AC (Vac)	Drive Carrier Frequency (KHz)	Power Loss at 100Hz (W)
.068.M100	600	<5	200
.100.M100	600	<5	200

### CONNECTIONS

Solid Cable (mm <sup>2</sup> )	LINE		PE
	Stranded Cable (mm <sup>2</sup> )	Terminal Block Torque (Nm)	Torque (Nm)
10-50	10-50	4.0	6
10-50	10-50	4.0	6

### TYPICAL MEASUREMENT

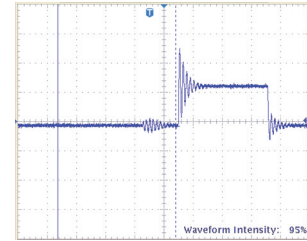

Typical measurement of dV/dt without snubber installed

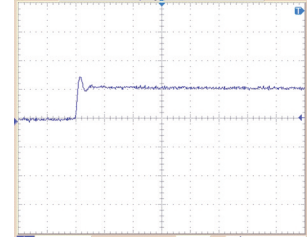

Typical measurement of dV/dt with snubber installed

### MECHANICAL DIMENSIONS mm

FINSTP	A	B	C	D	E	F	G	H	I	J	M	L	Weight Kg.	Case
.068.M100	190	167	185.5	125	110	83	105	5.4	4	8.5	10	20	4	1
.100.M100	190	167	185.5	125	110	83	105	5.4	4	8.5	10	20	4	1

### CASE 1

